

## Mirra® Chairs

Prices effective December 7, 2009

<b>Introduction</b>	<b>page 2</b>
<b>Mirra® Chairs</b>	<b>3</b>
Work Chair	5
Accessories	8
<b>Appendices</b>	
To view and/or print price book appendices, select the appropriate price book from <a href="http://www.HermanMiller.com">www.HermanMiller.com</a> .	

# Introduction

## A Note on the Organization of This Book

There are a few signals that will help you understand the organization of this book. Once you know them, you should be able to find your way around easily.

### Like a newspaper, this book is formatted with columns of text and illustrations that run vertically.

Information wraps from one column to the next and continues for as many pages as it needs to.

### Black bars are clues.

A black bar at the top of a page signals the start of information about a product.

This information is divided into two sections, each signaled by a black bar. Product Information includes a description, additional notes, and dimensional drawings. Specification Information, which always begins at the top of a column, includes a series of steps. Each step represents a decision you need to make in order to complete your product number. Steps must be followed sequentially. The number of pages needed to complete information on a product varies; some will be complete in one page; others may fill three or four pages. Just continue going through the steps until you run into the next product, signaled by the black bar at the top of the page.

Black tabs running along the outside edge of the page help you locate what section you are in or what section you want to go to. You can thumb forwards or backwards to find a section; tabs and text appear on both sides of the page.

The additional pages in the back of the book include the appendices and indices. They are signaled by a long black bar running along the outside edge of the page.

### The index is presented two ways.

The first index is in alphabetical order by product name. It can be helpful if you are new to the products and numbering scheme or if you are looking for a type of product, such as work chair or round table.

The second index is by product number. It lists, in alphanumeric order, the base product number, typically a five-digit number.

## General Information

This book is effective December 7, 2009, subject to change without notice. Products may be purchased from authorized Herman Miller dealers who will quote prices upon request. For more information about our products and services or to see a list of dealers, visit [www.HermanMiller.com](http://www.HermanMiller.com).

All prices are list prices. Additional services, such as planning services, design, storage, and installation, are not included and must be added to these prices when the additional services are requested.

Illustrations, specifications, and prices are based on the latest information at the time of publication. The right is reserved to make changes at any time without notice in prices, fabrics, finishes, materials, specifications, and models, and also to discontinue models and finishes.

Dimensions shown in the drawings are engineering drawing dimensions rounded up to the nearest  $\frac{1}{8}$ ". Product is shipped set up or knocked down. Products that include "Shipped knocked down" in the description require some assembly. If this statement does not appear in the description, the product is shipped assembled.

Service problems are normally handled by a Herman Miller authorized dealer. Where this cannot be accomplished on a local level, service problems should be referred to the Customer Care Representative for your region, Herman Miller, Inc., Zeeland, Michigan 49464.

### 20-Day or Less/Assigned Lead-Time Shipments

All products and options in this price book not designated by an Assigned Program icon  will ship in **20 business days or less** after being acknowledged by Herman Miller.

Products and options designated by an  are on the assigned lead-time program and may ship in 20 days, less than 20 days, or more than 20 days from order acknowledgement.

**Work Chair**

**Accessories**



## Work Chair

MR111  
MR112  
MR113  
MR121  
MR122  
MR123  
MR131  
MR132  
MR133

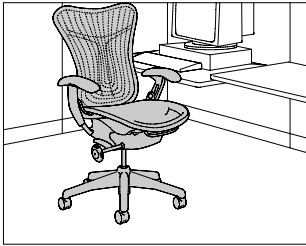

### Product Information

#### Description

This chair has an AireWeave™ seat-suspension material that is lightweight and breathable and evenly distributes the user's weight over the seat of the chair. The TriFlex™ back provides flexible and continuous support while providing airflow. The chair's Harmonic™ tilt provides continuous balance and lets the body recline naturally, pivoting at the ankles, knees, and hips. The chair has a 5-star base and 3 height-adjustment options: the low-height option has a seat-height range of 15" to 19 1/2"; the standard-height option has a seat-height range of 16" to 20 1/2"; and the extended-height option has a seat-height range of 16" to 21 1/2".

Tilt options include a standard tilt, tilt limiter, and tilt limiter and seat angle. The tilt limiter allows the user to set the tilt range to limit the amount of recline. The tilt limiter and seat angle allows the user to select the tilt range and either a horizontal or 4° forward seat angle.

Back options include a standard version and a user-adjustable lumbar support version. The adjustable lumbar support adjusts 4 1/2" in height and 1" in depth. Both back options include passive PostureFit® at the base of the back, below the beltline, that helps achieve healthier posture and improved lower back comfort.

The chair's TriFlex back can be specified with Latitude™ fabric on the front side. The applied fabric still allows flexible support and airflow.

Fabric cannot be applied to the chair's AireWeave seat.

Seat options include a 17" fixed seat depth or a FlexFront® seat depth that allows the user to adjust the seat depth from 17" to 19".

Arm choices include no arms, fixed arms, or 3-dimensional adjustable arms that adjust the arms 4" vertically, 1 3/8" horizontally, and pivot the arm pads 11° outward and 11° inward.

A fire-retardant chair meets CAL 133 requirements. The chair's seat, back, and tilt covers are manufactured with a fire-retardant additive. The additive does not meet Herman Miller's Design for the Environment criteria.

#### Notes

Chair is tested and warranted for use by persons 300 pounds and under.

To order chair knocked down, contact Customer Care.

For information on casters and glides, see Casters and Glides in Appendices.

### Dimensions

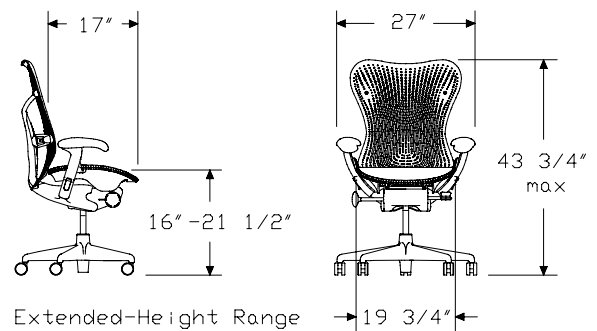
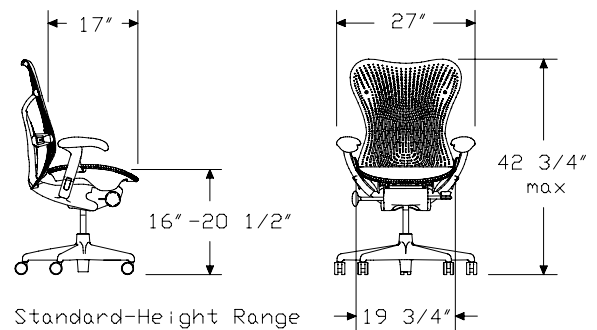
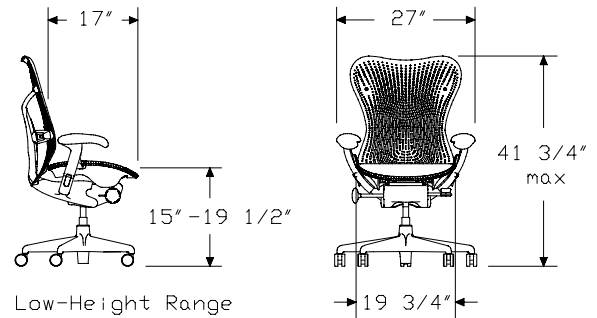

**Specification Information**

Step 1.

**MR1**

Step 2. Height Adjustment

- 1 low-height range
- 2 standard-height range
- 3 extended-height range A

Step 3. Tilt

- 1 standard tilt
- 2 tilt limiter
- 3 tilt limiter and seat angle

Step 4. Arms

- N** no arms
- P** fixed arms
- A** adjustable arms

Step 5. Seat-Depth Adjustment

- F** fixed seat depth
- A** FlexFront® adjustable seat depth

Step 6. Back

- M** TriFlex™ polymer back
- F** upholstered TriFlex™ polymer back

Step 7. Fire Retardancy

*For not fire retardant (\*), skip this step.*

- FR** fire retardant A

Prices for Steps 1-7.

			M*	MFR	F*	FFR
<b>MR111</b>	<b>N</b>	<b>F</b>	\$732	870	789	927
		<b>A</b>	\$789	926	845	983
	<b>P</b>	<b>F</b>	\$845	983	903	1041
		<b>A</b>	\$903	1041	959	1097
	<b>A</b>	<b>F</b>	\$920	1058	976	1114
		<b>A</b>	\$976	1114	1034	1172
<b>MR112</b>	<b>N</b>	<b>F</b>	\$771	909	829	967
		<b>A</b>	\$829	967	886	1024
	<b>P</b>	<b>F</b>	\$886	1023	942	1080
		<b>A</b>	\$942	1080	1000	1138
	<b>A</b>	<b>F</b>	\$959	1097	1017	1155
		<b>A</b>	\$1017	1155	1074	1212

<b>MR113</b>	<b>N</b>	<b>F</b>	\$817	955	874	1012
		<b>A</b>	\$874	1012	932	1070
	<b>P</b>	<b>F</b>	\$932	1069	988	1126
		<b>A</b>	\$988	1126	1046	1184
	<b>A</b>	<b>F</b>	\$1005	1143	1062	1200
		<b>A</b>	\$1062	1200	1120	1258

<b>MR121</b>	<b>N</b>	<b>F</b>	\$732	870	789	927
		<b>A</b>	\$789	926	845	983
	<b>P</b>	<b>F</b>	\$845	983	903	1041
		<b>A</b>	\$903	1041	959	1097
	<b>A</b>	<b>F</b>	\$920	1058	976	1114
		<b>A</b>	\$976	1114	1034	1172

<b>MR122</b>	<b>N</b>	<b>F</b>	\$771	909	829	967
		<b>A</b>	\$829	967	886	1024
	<b>P</b>	<b>F</b>	\$886	1023	942	1080
		<b>A</b>	\$942	1080	1000	1138
	<b>A</b>	<b>F</b>	\$959	1097	1017	1155
		<b>A</b>	\$1017	1155	1074	1212

<b>MR123</b>	<b>N</b>	<b>F</b>	\$817	955	874	1012
		<b>A</b>	\$874	1012	932	1070
	<b>P</b>	<b>F</b>	\$932	1069	988	1126
		<b>A</b>	\$988	1126	1046	1184
	<b>A</b>	<b>F</b>	\$1005	1143	1062	1200
		<b>A</b>	\$1062	1200	1120	1258

<b>MR131</b>	<b>N</b>	<b>F</b>	\$777	915	834	972
		<b>A</b>	\$834	972	891	1029
	<b>P</b>	<b>F</b>	\$891	1029	949	1087
		<b>A</b>	\$949	1086	1005	1143
	<b>A</b>	<b>F</b>	\$966	1103	1022	1160
		<b>A</b>	\$1022	1160	1080	1218

<b>MR132</b>	<b>N</b>	<b>F</b>	\$817	955	874	1012
		<b>A</b>	\$874	1012	932	1070
	<b>P</b>	<b>F</b>	\$932	1069	988	1126
		<b>A</b>	\$988	1126	1046	1184
	<b>A</b>	<b>F</b>	\$1005	1143	1062	1200
		<b>A</b>	\$1062	1200	1120	1258

<b>MR133</b>	<b>N</b>	<b>F</b>	\$863	1001	920	1058
		<b>A</b>	\$920	1058	976	1114
	<b>P</b>	<b>F</b>	\$976	1114	1034	1172
		<b>A</b>	\$1034	1172	1091	1229

<b>A F</b>	\$1051	1189	1108	1246
<b>A</b>	\$1108	1246	1164	1302

**Step 8. Back Support Option**

<b>N2</b>	no additional support			+\$0
<b>AJ</b>	adjustable lumbar support			+\$60

**Step 9. Base/Frame Finish**

*For fixed arms (P), adjustable arms (A) with not fire retardant, no arms (N) with fire retardant (FR) fixed arms (P), adjustable arms (A) with fire retardant (FR), or no arms (N) with not fire retardant*

<b>G1</b>	graphite			+\$0
<b>ZR</b>	shadow			+\$0

**Step 10. Casters/Glides**

<b>BB</b>	2½" hard caster, black yoke, carpet			+\$0
<b>GF</b>	2½" glide, hard floors or carpet			+\$0
<b>C7</b>	2½" caster, black yoke, hard floors or carpet			+\$40
<b>C9</b>	2½" braking caster, black yoke, hard floors or carpet			+\$40

**Step 11. Back Finish**

*For not fire retardant*

<b>G1</b>	graphite			+\$0
<b>ZJ</b>	citron			+\$0
<b>ZK</b>	cappuccino			+\$0
<b>ZL</b>	felt green			+\$0
<b>ZM</b>	alpine			+\$0
<b>ZN</b>	blue fog			+\$0
<b>ZP</b>	terra cotta			+\$0
<b>ZR</b>	shadow			+\$0

*For fire retardant (FR)*

<b>G1</b>	graphite <span style="border: 1px solid black; padding: 0 2px;">A</span>			+\$0
-----------	--	--	--	------

**Step 12. Armpad Finish**

<b>BK</b>	black			+\$0
<b>ZT</b>	shadow grey			+\$0

**Step 13. AireWeave™ Suspension Material**

*See application chart and textiles list for fabric usage and numbers. First 2 digits of number indicate fabric line; remaining digit(s) indicate fabric color.*

*For not fire retardant with graphite (G1), fire retardant (FR) with graphite (G1), not fire retardant with shadow (ZR), or fire retardant (FR) with shadow (ZR)*

Price Category 1	+\$0
------------------	------

**Step 14. Latitude™ Fabric**

*For upholstered TriFlex™ polymer back (F)*

*See application chart and textiles list for fabric usage and numbers. First 2 digits of number indicate fabric line; remaining digit(s) indicate fabric color.*

Price Category 3	+\$40
------------------	-------

# Upholstered Back Kit

MR910

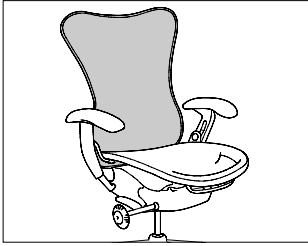

Mirra® Accessories

### Product Information

#### Description

This upholstered back replaces an existing back on a Mirra® work chair. Its TriFlex™ back is upholstered with Latitude™ fabric on the front side. The applied fabric allows flexible support and airflow.

#### Notes

Specify upholstered back kit's frame finish to match Mirra work chair's frame finish.

Existing Mirra chair's lumbar strap or fixed back loop finish should match molded back finish. To change existing chair's lumbar strap finish, order adjustable lumbar kit (MR905A) separately. To change existing chair's fixed back loop finish, order fixed lumbar kit (MR905F) separately.

### Specification Information

#### Step 1.

**MR910** \$139

#### Step 2. Frame Finish

<b>G1</b>	graphite	+\$0
<b>ZR</b>	shadow	+\$0

#### Step 3. Back Finish

<b>G1</b>	graphite	+\$0
<b>ZJ</b>	citron	+\$0
<b>ZK</b>	cappuccino	+\$0
<b>ZL</b>	felt green	+\$0
<b>ZM</b>	alpine	+\$0
<b>ZN</b>	blue fog	+\$0
<b>ZP</b>	terra cotta	+\$0
<b>ZR</b>	shadow	+\$0

#### Step 4. Latitude™ Fabric

See application chart and textiles list for fabric usage and numbers. First 2 digits of number indicate fabric line; remaining digit(s) indicate fabric color.

Price Category 3 +\$40

# Lumbar Kit

MR905

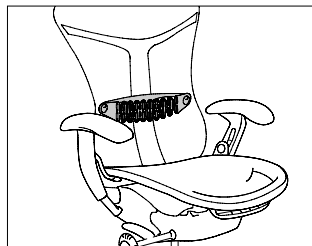

### Product Information

#### Description

This adjustable lumbar support fits into the back of a Mirra® work chair. It adjusts 4½" in height and 1" in depth.

#### Notes

Lumbar kit's support bow finish matches Mirra chair's frame finish.  
Lumbar kit's lumbar strap finish matches Mirra chair's molded back finish.

### Specification Information

#### Step 1.

**MR905A** \$78

#### Step 2. Support Bow Finish

<b>G1</b>	graphite	+\$0
<b>ZR</b>	shadow	+\$0

#### Step 3. Lumbar Strap Finish

<b>G1</b>	graphite	+\$0
<b>ZJ</b>	citron	+\$0
<b>ZK</b>	cappuccino	+\$0
<b>ZL</b>	felt green	+\$0
<b>ZM</b>	alpine	+\$0
<b>ZN</b>	blue fog	+\$0
<b>ZP</b>	terra cotta	+\$0
<b>ZR</b>	shadow	+\$0

Mirra® Accessories

# Arm Kit

MR900



### Product Information

#### Description

These arms retrofit to a Mirra® work chair. They adjust 4" vertically, 1<sup>3</sup>/<sub>8</sub>" horizontally, and pivot the armpads 11° outward and 11° inward.

Mirra® Accessories

### Specification Information

#### Step 1.

**MR900**

#### Step 2. Arms

**A** adjustable arms

#### Prices for Steps 1-2.

**MR900 A** \$189

#### Step 3. Frame Finish

**G1** graphite +\$0

**ZR** shadow +\$0

#### Step 4. Armpad Finish

**BK** black +\$0

**ZT** shadow grey +\$0

For more information about our products and services or to see a list of dealers, please visit us at [www.HermanMiller.com](http://www.HermanMiller.com) or call (800) 851 1196.

This book is recyclable. Printed in U.S.A. on recycled paper.

© 2009 Herman Miller, Inc., Zeeland, Michigan

© HermanMiller, , Abak, Action Office, Aeron, Ambi, Ardea, Aside, Avive, Babble, C2, Caper, Celle, Co/Struc, DOT, Eames, Embody, Equa 2, Ergon 3, Ethospace, Fine-Tune, FlexFront, Formcoat, Ground Cloth, Herman Miller for Healthcare, Herman Miller Options, Intersect, Kinemat, Leaf, Lifework, Limerick, Meridian, Mirra, Passage, Pedastool, Pellicle, Perspectives, PostureFit, Prospects, Quadrant, Reaction, Resolve, RoomTune, Scooter, Stoa, Teneo, V-Wall, Vary Easy, Vivo, and Z-Axis are among the registered trademarks of Herman Miller, Inc., and its owned subsidiaries.

™ About Face, AireWeave, Airia, Arrio, Backfit, Boomerang, Bubbletack, Burdick Group, Celeste, Cellular Suspension, CLT, CoActive, Cognita, Compass, Cygnus, Enchord, EnhancedAccess, E-Wall, Flex-Edge, Flute, Harmonic, Herman Miller for the Home, Herman Miller International Collection, Herman Miller Select, Hopsak 2, Intent, Iota, Keyless Entry, Latitude, Lyris, Multiscrim, My Studio Environments, Nelson, Pixelated Support, Programmable Environments, Q, Rapunzel, Recline Selector, Sense, Setu, Stackable, Stackable Storage, The Be Collection, Thinking is good for you, TriFlex, Tu, and Twist are among the trademarks of Herman Miller, Inc., and its owned subsidiaries.

SM TAP, Textile Alliance Program and Thoughtpile are among the service marks of Herman Miller, Inc.

Chemsurf is a registered trademark of Wilsonart International.

Corian is a registered trademark of DuPont.

FLEXNET is a trademark of Milliken & Co.

Floor Saver Glide™ is a trademark of Carpin Manufacturing Inc.

Geiger is a registered trademark of Geiger International.

Goetz is a trademark of Mark W. Goetz.

Hang-It-All is a registered trademark of Lucia Eames Demetrios, d.b.a. Eames Office.

Holophane is a registered trademark of Holophane.

Ingeo is a trademark of Cargill Dow LLC.

Microsoft and Natural Keyboard are registered trademarks of Microsoft Corporation.

Noguchi® is a registered trademark of The Isamu Noguchi Foundation and Garden Museum.

Qt Quiet technology and Qt are trademarks of Cambridge Sound Management, Inc.